



www.austineighteenhundred.com.au

READERS' CONTRIBUTIONS

“The Ignition Coil”

An article by Tony Cripps

As nearly all Austin 1800 know, the standard ignition system on our cars consists of points, condenser, coil, distributor, and spark plugs. This highly evolved system was preceded by trembler coil and hot wire methods. As is now well known, in our systems it is the switching action of the mechanical points that induces a high voltage in the ignition coil which is sufficient to create a hot spark at the spark plug inside the cylinder. The distributor itself distributes this spark to the correct spark plug at the correct time in the compression stroke.

However, there are some details about this process that are worth knowing in case of problems and modifications.

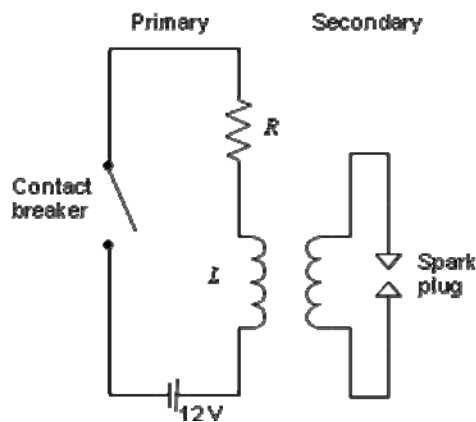

The above diagram shows the general arrangement. The whole thing depends upon Faraday's law of induction. This law states that the induced voltage in a coil depends upon the rate of change of current through the coil and the nature (the “inductance”) of the coil. So, when the points are closed, current flows from the battery into the primary side of the ignition coil. The rate of change of current during this process depends upon the resistance of the coil, the inductance of the coil, and the voltage applied to the coil.

There is an equation that describes how the current changes in the coil when the points close:

$$i = \frac{V}{R} \left(1 - e^{-\frac{Rt}{L}} \right)$$

In this equation, i is the primary current at some time t , V is the 12 V applied to the coil, R is the resistance of the primary, L is the inductance of the coil and “ e ” (if you were wondering and are still with us) is the base of Naperian logarithms. Having got that out of the way, we can go back to what we really want to know.

What this equation tells us is that the current increases like this:

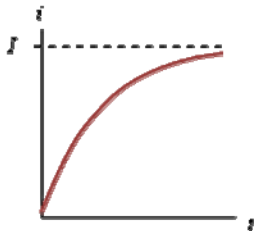

when plotted against time. The initial rate of increase in current is often called the “time constant”. We want the time constant to be fairly short because the points are only closed for a brief time, and if the rate of current increase is too slow, then we will not get a very good build up of current flowing in the primary during the time available that the points are closed. You will see in a moment why this is important. As the rpm of our engine increases, the rate of current rise in the primary has to be even shorter to take into account the even less time that the points remain closed.

So, what determines this *rate* of current rise in the primary? The equation above tells us. By employing a little bit of mathematics, it can be shown that the rate of current increase is:

$$\frac{\Delta i}{\Delta t} = \frac{V}{L} e^{-\frac{R}{L}t}$$

@ $t = 0$

$$\frac{\Delta i}{\Delta t} = \frac{V}{L}$$

where I is the final current reached after a long time. At $t = 0$, we get the initial rate of increase. This says that the initial rate of increase is greater when the inductance of the coil is low. Essentially what is happening is that the current in the primary creates a magnetic field (much like an electromagnet). When this field *changes* (by virtue of the current increasing or decreasing), the changing magnetic field induces a voltage in the secondary coil (much like a generator does). The problem is that we need a fairly large inductance to generate a high voltage in the secondary because the induced voltage in the secondary is given by:

$$V_{sec} = L \frac{\Delta i_p}{\Delta t}$$

The second equation also tells us that the rate of increase in the primary current depends upon V - the battery voltage (12V). If the battery voltage falls (such as it almost certainly does when the engine is cranked over by the starter motor) the rate of increase in I in the primary also falls.

In the third equation, this secondary voltage V_{sec} is induced when the points close, and again when the points open. However, we only get a spark when the points open because the rate of current increase (or decrease – it is the *change* in current that is important), isn’t large enough when the point close to induce a high enough voltage to cause a spark.

Things are different when the points then open. The current in the coil is immediately stopped, and therefore the rate of current decrease is very high – because it is switched off, the circuit is broken. This causes the magnetic field from the primary to collapse very rapidly and the voltage V_{sec} is high enough to cause the molecules in the space between the spark plug gaps to become conducting and we see a visible spark. This spark is hot, and it is the temperature of the spark that then ignites the fuel/air mixture.

So, what does this mean for us in our Austin 1800’s?

Ballast Resistor:

Austin 1800's (in Australia) were not fitted with ballast resistors that are seen on some cars, but it is worth knowing what they are for. The ballast resistor is placed in series with the primary side of the coil. Its resistance changes with temperature (doubling or tripling its resistance from cold to hot). The resistor is often bypassed by the cranking circuit. What this ballast resistor does is to make the process of ignition more reliable when cranking a cold engine. The ignition coil is designed to work on about 8 to 10V. When the starter motor is engaged, the battery voltage drops to about 10 V, and so this is applied directly to the coil. The coil is designed to have an acceptable rate of current rise when 10V is applied to its primary. It does this by having a lower primary resistance in its windings. When cranking stops and the engine is running, the primary current (now passing through the ballast resistor) causes the resistor to heat up and become more resistive, and so the 12 V gets lowered to about 10 V or so for the coil. Thus, the ignition coil operates at about 10 V all the time.

If you use a coil designed for a ballast resistor without the resistor, the 12 V battery voltage will be applied directly across the primary winding and it will become very hot, draw a lot of current, and burn out the points in short order.

Condenser:

The condenser, or capacitor, absorbs the electric shock of the points opening and closing. Without the condenser, the points will burn out from arcing. If arcing occurs, the change in current in the primary will not be so rapid and the production of the required secondary voltage will be impaired – that is, the engine will misfire.

Coil:

Experiments show that the most efficient spark occurs when the centre electrode is negative in polarity with respect to the engine block. The polarity of the spark depends upon the polarity of the voltage applied to the primary terminals. So, it is important (but not absolutely necessary) that the terminals marked "CB" and "SW" (for contact breaker and ignition switch) are correctly connected.

The coil, as some will know, is filled with oil. The process of induction and current flow in both primary and secondary is not 100% efficient. That is, considerable heat is generated in the coil when it is operating. The oil serves to insulate the windings, provide a method of cooling, and also, assists in contributing to the inductance of the device by virtue of its electrical properties (the oil's permittivity). You will find that large power transformers are often immersed in oil for the same reasons.

Contact breaker

The action of the contact breaker is essential for good running. The contact breaker has to open and close at the right time, and remain closed for a long enough time for current to build up in the primary, open smartly so that a high voltage is induced in the secondary, and all at high speed. Mechanically, this depends on the profile of the cam lobes in the distributor. The shape of this cam is a compromise between good electrical performance and acceptable insensitivity to variations in contact gap caused by mechanical wear and user skill in setting the gap. In short, one must adhere to the manufacturer's dwell angle as closely as possible.

Electronic ignition

These days, electronic systems are the norm, and many Austin 1800 owners have fitted such systems to their cars. The simplest, and probably the easiest, is to replace the mechanical points and condenser with a solid state switch. This has the advantage of retaining the original exterior appearance of the distributor. An important point when fitting this system is to apply the white heat conduction compound (that should be supplied with the kit) to the base of the switch body so that heat generated inside the switch (by the large power transistor contained therein) will not overheat and fail.

Despite being more reliable, and able to be more accurately controlled by a computer, electronic systems still rely on Faraday to induce a spark at the spark plug and so the principles above are still relevant.

After reading all of the above, one gets an appreciation of how many things work together to form a working ignition system that has to cater for a wide range of operating conditions.